

Considerable flexibility thanks to modular structure and expandable licences

Direct marketing, smart energy & feed-in management functions

Simple plug & play installation thanks to DIN rail mounting

Integrated bus analysis function



Models	Plant size	Article Number
Solar-Log™ Base 15	15 kWp	256325
Solar-Log™ Base 15V2	15 kWp	257300
Solar-Log™ Base 100	100 kWp	256326
Solar-Log™ Base 2000	2000 kWp	256327

# Solar-Log™ Base

## Our Most Powerful PV Energy Management System Ever

---

### Your added Value and Benefits

The new revolutionary Solar-Log™ generation combines smart functionality with greater flexibility for more efficient control, management and monitoring of PV plants. For you, this means:

- **Security**  
Easily and effectively implement regulations for feed-in management.
- **Valuable time savings**  
Easily DIN rail mounted for simple installation.
- **Optimal price**  
You only have to purchase the functions you need for your plant requirements.

### Function

#### **Modular design – customised to your needs**

Functions can be individually combined for each PV plant in accordance with requirements. Interface elements and various software licences can be purchased according to the needs of the system operator.

#### **Installation licence – cleverly identifies which licences are required**

With the Solar-Log™ Base devices, the required licences are already activated free of charge for 30 days during the installation. Within this period, the licences can then be purchased and registered conveniently from your office in the [Solar-Log™ Shop](#).

#### **The innovative bus analysis feature replaces the oscilloscope**

With the Solar-Log™ Base models, you can measure and evaluate the signal quality of the inverter communication (RS485).

#### **Solar-Log™ Base Direct Marketing – VPN Function**

Previously, an external router was required to transmit data to the direct marketer. It is possible to make secure VPN data transfers without any additional hardware. This integration not only saves money from the hardware, but also the installation. In addition, Solar-Log™ now offers a complete solution for Redispatch 2.0\*\*.

\*PV Monitoring works with Solar-Log WEB Enerest™ 4 Monitoring Plattform  
\*\* Only relevant for the German market

### **Smart Energy - More Self-sufficiency than Ever Before**

Recording and presentation of self-consumption control and visualization of individual appliances for the optimization of self-consumption.

### **Feed-in Management – Guarantees Compliance with the Legal Requirements**

Reduction of feed-in power with a dynamic allowance for self-consumption.

## **Display Options**

### **Solar-Log WEB Enerest™ 4\* - Powerful performance in securing yields**

The new online portal features an attractive new design and numerous features. The new features, such as system fault detection, workflow optimisation and accelerated troubleshooting.

### **The Enerest ToGo app for the Solar-Log WEB Enerest™ Portal – intuitive and free of charge**

This app offers users comfort and security with its structured operating concept, intuitive controls, modern features and interactive graphics. The app is available for free from the Apple App store and Google Play Store.

### **Solar-Log™ Pinboard & Slideshow**

With the Solar-Log™ pinboard, Solar-Log WEB Enerest™ 4 dynamically displays all important information about the plant such as the yield and performance. For this purpose the pinboard can be individually configured with various widgets. All existing pinboards can be displayed with the slideshow. This function also fulfils the requirements for visualising PV systems stipulated by KfW 40 Plus\*.

### **Large external display (RS485) – Present your PV Plant Data**

A large external display used in combination with the Solar-Log™ can visually present live data from a PV plant. You can also add personalized advertisements. Large external displays can be connected via the RS485 interface.

### **VDE- 4110\*\* with the Solar-Log™ Base – compliant, safe, flexible and convenient.**

In 4 simple steps to successful VDE commissioning with our support.

\* Licence fees may apply for the use of the Solar-Log WEB Enerest™ 4 Portal.

\*\* Only relevant for the German market

# Connections

## Components

The Solar-Log™ Base is compatible with all standard inverter models. Compatible battery storage units, heat pumps, charging infrastructure and other Smart Energy components can also be connected. You can find details on these in our [component database](#).

### 1 x S<sub>0</sub> in

For connecting meters with S<sub>0</sub>in interface.

### 2 x RS485 or 1 x RS422

For connecting components with RS485 or RS422 interfaces.

### 2 x Ethernet

For connecting to the internet and components with Ethernet interface.

## USB Connection

A USB stick can be connected for safe and quick manual installations of new firmware updates, configurations, and backups.

# Licences

You can increase the performance limits of the Solar-Log™ Base with the Solar-Log™ Base extension licence.

<b>Expandable Licences *</b>	<b>Solar-Log™ Base 15/15V2</b>	<b>Solar-Log™ Base 100</b>	<b>Solar-Log™ Base 2000</b>
Solar-Log™ Base extension licence	from 15 kWp to 30 kWp	from 100 kWp to 250 kWp	-
Article number	256328	256329	-

\* With additional costs

Interfaces

RS485/RS422	2 x RS485 or 1 x RS422		
Ethernet network <sup>1)</sup>	2 x 100 Mbit/s		
USB connection <sup>2)</sup>	2 x USB 2.0		
S <sub>0</sub> in	1 x S <sub>0</sub>		

Basic Functions

Maximum plant size	15 kWp	100 kWp	2 MWp <sup>3)</sup>
Inverter connection options	Ethernet, 2x RS485 or 1x RS422 <sup>4)</sup>		
Battery storage: visualization, charging time shifts	●	●	●
Smart Energy	●	●	●
Powermanagement	●	●	●
Direct Marketing	●	●	●
Bus Analysis Function	●	●	●
Maximum cable length <sup>5)</sup>	Maximum cable length 1000 m twisted pair		

Extension licences

Expandable licence for max. plant size	up to 30 kWp	up to 250 kWp	-
Solar-Log™ interconnection control licence	●	●	●
Modbus TCP direct marketing licence	●	●	●
Modbus TCP PM licence	●	●	●
Solar-Log™ PM PRO licence	●	●	●
SCB Software licence	-	●	●

Additional function interfaces via the Solar-Log™ HBUS module connector <sup>6)</sup>

Digital control outputs	via an additional module (Solar-Log™ MOD I/O) <sup>7)</sup>
Digital control inputs	via an additional module (Solar-Log™ MOD I/O) <sup>7)</sup>
Interface for a ripple control receiver (PM+)	via an additional module (Solar-Log™ MOD I/O) <sup>7)</sup>
RS485 <sup>9)</sup>	via an additional module (Solar-Log™ MOD 485) <sup>7)</sup>
RS422 <sup>9)</sup>	via an additional module (Solar-Log™ MOD 485) <sup>7)</sup>

Visualization

Integrated web servers	●	●	●
Graphic visualization	local and portal <sup>8)</sup>		
Multilingual (DE, EN, ES, FR, IT, CN)	●	●	●
Recording duration: Daily, monthly, annual values	up to 10 years		
TFT Display	● / -	●	●

## Technical Data

### Solar-Log™ Base 15/15V2    Solar-Log™ Base 100    Solar-Log™ Base 2000

Display on the device	● / -	●	●
Data transfer to external portals <sup>10)</sup>		API, ftps, ftp	
HTTP data transfers to Solar-Log WEB Enerest™ for low data volumes	●	●	●
Compatible with large external display (RS485 and Modbus TCP)	●	●	●

## Installation

Power supply unit <sup>11)</sup>	Depending on the output voltage (24V DC (+-5%), if required 12V DC (+-5%)), observe component requirement		
Installation wizard	●	●	●
Network detection / DHCP	●	●	●
Name resolution solar-log	●	●	●

## Powermanagement

Reduction to X percent (with and without the calculation of self-consumption)	●	●	●
Control PV systems for providing active and reactive power (VDE 4110-compliant) <sup>12)</sup>	●	●	●

## Plant Monitoring

Inverter alarms (failure, status, error and power deviation messages) in the portal	●	●	●
Yield forecast	●	●	●
MPP Tracker Comparison	●	●	●
Sensor system connection (irradiation / temp. / wind)	●	●	●
Self-produced energy consumption; Digital electricity meter	●	●	●
Self-produced energy consumption: Managing external appliances	●	●	●

## General Data

Device voltage <sup>13)</sup>	24V DC (+-5%), if required 12V DC (+-5%)		
Device current <sup>13)</sup>	max. 1 A		
Power consumption	typ. 2,4 W		
Memory	4 GB internal		
Real-time clock (RTC)	Battery buffered in case of power failure		
Dimensions / Weight	Housing / Dimensions (W x H x D)	3TE / 53,6mm x 89,7 mm x 60,3mm	
	Height from top edge of mounting rail	~54,5 mm	
	Net weight	112 g (Solar-Log™ Base 15V2: 100 g)	

Mounting type	DIN rail	TH 35 / 7,5 or TH 35 / 15 to IEC/EN 60715
	Wall mounting	Mounting / screw clips (without DIN rail or additional modules)
Connection data	Connection technology	Push-in SPRING CLAMP®
	Solid conductor	0,2 ... 1,5 mm² / 24 ... 16 AWG
	Fine-stranded conductor	0,2 ... 1,5 mm² / 24 ... 16 AWG
	Fine stranded conductor with ferrule	0,14 ... 1 mm²
	Stripping length	8.5 ... 9.5 mm / 0.33 ... 0.37 inch, with ferrules ≥ 6 mm. Please note the diameter of the plastic collar
Material data	Housing material	PC/ABS
	Colour	black
Ambient conditions	Ambient temperature	-20°C to +50°C (without condensation)
	Ambient temperature storage/transport	-20°C to +60°C
	Protection rating to EN 60529	IP20
	Mounting position	any
Warranty		2 years
Conformity marking		CE

- 1) No switch function. Only use Ethernet 2 interface for components.
- 2) USB interfaces for the specific use of enabled functions (firmware updates, configuration and data backups).
- 3) Several Solar-Log™ Bases can be combined into a virtual system in the portal for visual display purposes. An interconnection control licence is necessary if the PV plant needs to be completely controlled.
- 4) An RS485 meter cannot be connected when using RS422.
- 5) Depending on the inverter used, cable type and electrical boundary conditions (specifications may vary depending on the device type).
- 6) Additional modules connected to the Solar-Log™ Base are supplied with power and voltage via the Solar-Log™ HBUS module connector. The following aspects must be observed in this regard:
  1. The supply voltage on the Solar-Log™ HBUS module connector corresponds to the supply voltage on the Solar-Log™ Base.
  2. If the connected modules are not supplied separately with a higher voltage when required, the voltage at the outputs corresponds to the supply voltage at the Solar-Log™ HBUS module connector.
  3. The Solar-Log™ MOD I/O outputs can draw a maximum of ~0.4A from the Solar-Log™ HBUS module connector. If more current is required in total at the Solar-Log™ MOD I/O outputs, the Solar-Log™ MOD I/O must be supplied separately with its own power supply unit of sufficient capacity (note: a maximum current of ~0.15A is possible per Solar-Log™ MOD I/O output).
  4. If external components are to be supplied via the voltage outputs of the interfaces, an additional voltage supply for the Solar-Log™ MOD 485 module is essential.
- 7) Maximum number of expansion modules = 1 Solar-Log™ MOD I/O and/or 1 Solar-Log™ MOD 485.
- 8) Licence fees may apply for the use of the Solar-Log WEB Enerest™ 4 Portal.
- 9) Can only be used with Solar-Log™ Base firmware 6.x or higher.
- 10) Licence for a fee.
- 11) Only use NEC Class 2 power supplies for installations in the US market.
- 12) Further components (e.g. a PM package) may be necessary depending on the requirements of the energy supplier. You can find more details in our feed-in management section.
- 13) The Solar-Log™ Base and the Solar-Log™ MOD 485 module may only be supplied with 12V DC when used in conjunction with the special Piggy Back (Art 220020). Please also note the power supply for sensor boxes via the bus.

No power supply unit is included in the scope of delivery.

## Connection

### Top

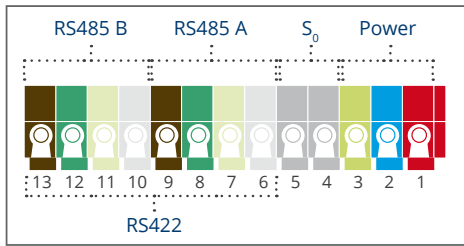

### Bottom

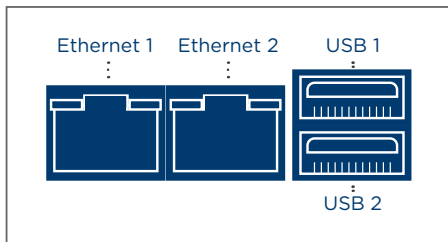

Pin	RS485	RS422	Power	S <sub>0</sub> in
1	-	-	Vin 24VDC / (12 VDC)	-
2	-	-	GND	-
3	-	-	FE	-
4	-	-	-	S <sub>0</sub> IN +
5	-	-	-	S <sub>0</sub> IN -
6	Data +	T/RX+	-	-
7	24 V / (12 V)	24 V / (12 V)	-	-
8	Ground / GND	Ground / GND	-	-
9	Data -	T/RX-	-	-
10	Data +	R/TX+	-	-
11	24 V / (12 V)	-	-	-
12	Ground / GND	-	-	-
13	Data -	R/TX-	-	-

## Technical drawings

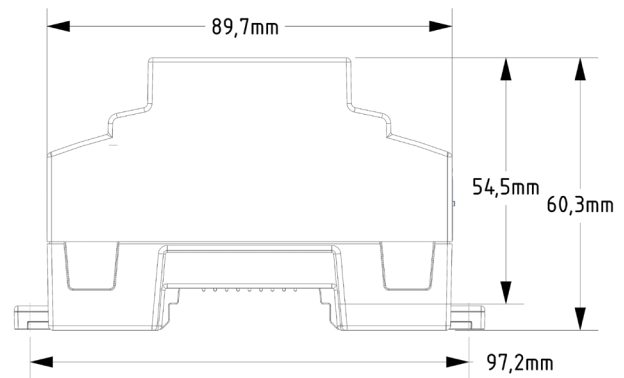
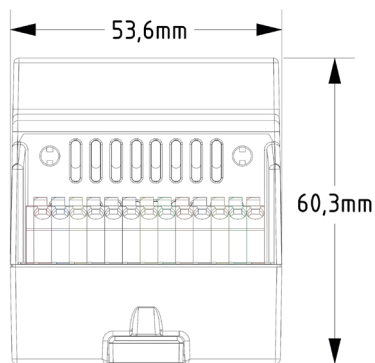

### Inverter interfaces

RS485/RS422 – interface	2x RS485 or 1x RS422	2x RS485 or 1x RS422	2x RS485 or 1x RS422
	Inverter connection (Fronius / Sunville can be connected on an RS422 interface without an additional interface converter)		
	Connection of a Sensor Box Professional Plus to record environmental data (irradiance, module and ambient temperature, wind sensor)		
	Sensor Box Professional		
RS485/RS422 – interface usage	Meter connection, numerous options		
	Connection of the display panels produced by Schneider Displaytechnik, Rico or HvG		
	Solar-Log™ Smart Relay Box connection for the management of consumption data		
	-	-	Connecting the Utility Meter

### Additional interfaces

S <sub>0</sub> -In	S <sub>0</sub> pulse input – for optional recording and calculation of self-produced power consumption
	Input to connect an additional power meter
USB Connection	To access data / Import firmware updates
PM+	Only possible with Solar-Log™ MOD I/O
Network	Connection to the internet (Ethernet, fixed IP address or DHCP)

**Power supply**

Gateway Solar-Log™ 50/ Base power supply	256226	●	●	●
Gateway Solar-Log™ 50/ Base top-hat rails power supply	256227	●	●	●

**Relays**

Solar-Log™ Smart Relay Station V2 <sup>1)</sup>	257257	●	●	●
Solar-Log™ Smart Relay Box	255656	●	●	●

**Smart Heater**

AC ELWA 2	257274	●	●	●
AC THOR	257255	●	●	●
AC THOR 9s	257256	●	●	●

**Meters**

Solar-Log™ PRO380	255913	●	●	●
Solar-Log™ PRO380-CT	256059	●	●	●
Solar-Log™ PRO1	255914	●	●	●
Solar-Log™ PRO2	256324	●	●	●
Utility Meter UMG 104	255385	● <sup>2)</sup>	● <sup>2)</sup>	●
Utility Meter UMG 604 E-PRO (24V)	257272	● <sup>2)</sup>	● <sup>2)</sup>	●
Utility Meter UMG 604 E-PRO	257197	● <sup>2)</sup>	● <sup>2)</sup>	●

**Sensors**

Sensor Box Professional Plus	220060	●	●	●
Sensor Box Professional	255896	●	●	●
Lufft (e. g. WS 501 UMB)	On request	●	●	●
Kipp&Zonen (Pyranometer)	On request	●	●	●

1) The Smart Relay Station V2 is supported starting with firmware version 6.0.

2) Can only be used as a consumption meter with firmware lower than 6.X.